

AeroMed® LEXUS™ Upper-Room Germicidal Open UV Fixture

AeroMed® Integrity

As a trusted partner for critical environmental applications, we are committed to serving our clients' needs with integrity, honesty and trust.

AeroMed® Reputation

AeroMed environmental infection control products are used by healthcare facilities and clinical researchers around the world.

AeroMed® Engineering

AeroMed products are designed specifically for critical applications like yours. We have unparalleled product flexibility leading to equipment that better fits your specific needs.

AeroMed® Technologies, LLC

1821 Broad Street
Utica, NY 13501
Phone: +1.518.843.3500
Fax: +1.315.732.4238
Web: www.AeroMed.com



General Overview

The AeroMed® LEXUS™ upper-room open GUV (germicidal ultraviolet) fixtures are designed to irradiate air in occupied spaces, with tall ceilings, that may contain infectious pathogens.

These fixtures have historically been used for airborne-spread germs, such as SARS (coronavirus), influenza, tuberculosis, and measles. The WHO recommended the use of Upper room GUV for tuberculosis infection prevention and control in their 2019 guidelines.

Some facilities in which the LEXUS™ are now commonly applied would be:

- Hospitals
- Restaurants
- Schools and Universities
- Health Clinics
- Fitness and Sports Centers
- Dental Offices
- Commercial Office Settings
- Prison Health Clinics
- Government Offices
- Voting Centers
- Homeless Shelters
- Day care / nurseries

What makes us better?

- *Highest UV output provides best protection for tall spaces*
- *Independent laboratory tested for UV output*
- *Best Combination of performance and economy*
- *With higher output, fewer units may be required*
- *Easily adjustable for safety testing*

LEXUS™ Open fixtures are designed for tall spaces greater than 12' (3.7 m). The higher output of the open fixtures dramatically reduces the number of fixtures required to treat a space!

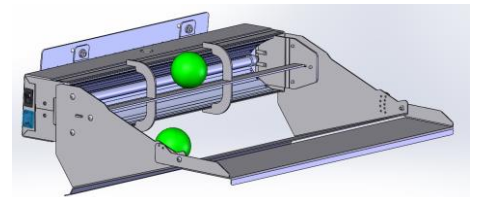

“Upper-room germicidal ultraviolet (GUV) systems are recommended to reduce M. tuberculosis transmission to health workers, persons attending health care facilities or other persons in settings with a high risk of transmission.”

[WHO guidelines on tuberculosis infection prevention and control, 2019 update](https://www.who.int/publications/m/item/who-guidelines-on-tuberculosis-infection-prevention-and-control-2019-update)

For service and safety testing instructions visit:

<http://www.stoptb.org/wg/ett/>

LEXUS™ Upper-room Germicidal Open UV Fixture

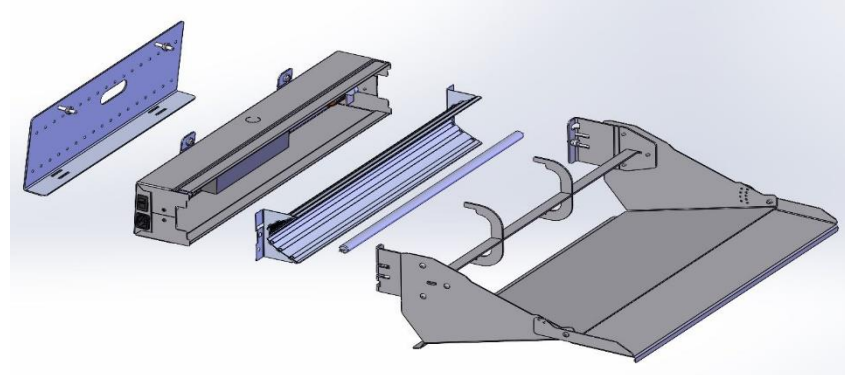

The Geometry of a parabolic reflector (shown above) is such that all energy coming from a UV lamp correctly located in the focal point is emitted from the fixture as parallel or collimated light.

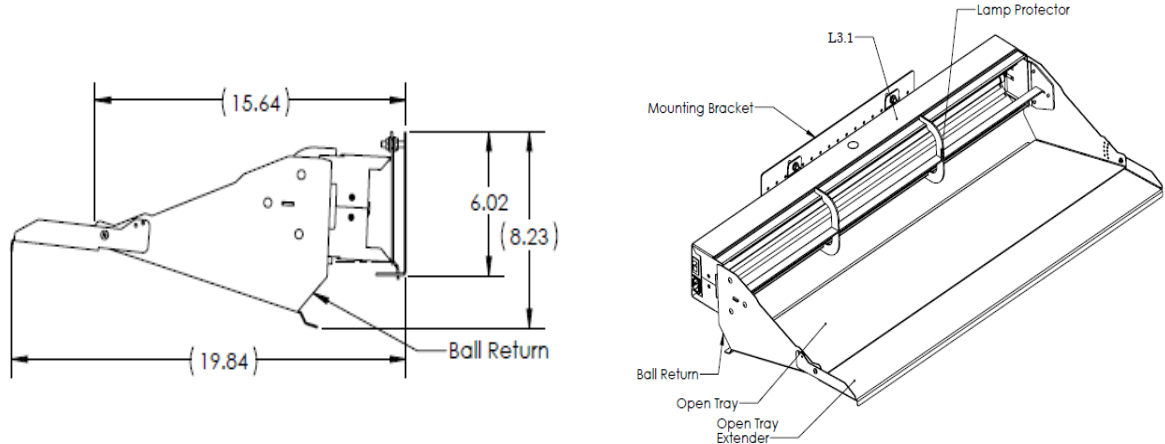

AeroMed® Innovation

AeroMed continues to drive the evolution of airborne infection control engineering in healthcare and all settings where healthy indoor air is a necessity.

AeroMed® Compliance

Through our products, services and consulting, AeroMed partners with your facility to achieve and maintain compliance with industry codes, standards and guidelines.

AeroMed® Experience

With over thirty-five years of experience in environmental infection control, AeroMed has unparalleled experience in the healthcare industry.

AeroMed® Technologies, LLC

1821 Broad Street
Utica, NY 13501
Phone: +1.518.843.3500
Fax: +1.315.732.4238
Web: www.AeroMed.com

AM-LEXUS-OPEN Specifications

	Imperial Units		SI Units	
Unit:	LEXUS™ L2.1 Open	LEXUS™ L3.1 Open	LEXUS™ L2.1 Open	LEXUS™ L3.1 Open
Height:	6.02"	6.02"	153 mm	153 mm
Width:	23.25"	34.9"	591 mm	886 mm
Depth:	19.84"	19.84"	504 mm	504 mm
Weight:	7 lbs	9 lbs	3.18 kg	4.08 kg
Nominal Power:	26.2W	40.6W	26.2W	40.6W
Plug Choices:	A/B	A/B	C/D/M/N	C/D/M/N
UV Lamp:	AM-LX-UVL	AM-LX-UVL-Max	AM-LX-UVL	AM-LX-UVL-Max
UV Output: <small>By independent lab</small>	3.71 watts	6.25 watts*	3.71 watts	6.25 watts*
Voltage:	100 - 277 volts		100 - 277 volts	
Note:	auto detects voltage * estimated based on L2.1 output		auto detects voltage * estimated based on L2.1 output	

WH Guidelines on Tuberculosis Infection Prevention and Control, 2019 Update are available here:

<https://apps.who.int/iris/bitstream/handle/10665/311259/9789241550512-eng.pdf>